

Model #EQ-8 Six point, tube mount mirror cell for an 8 inch mirror

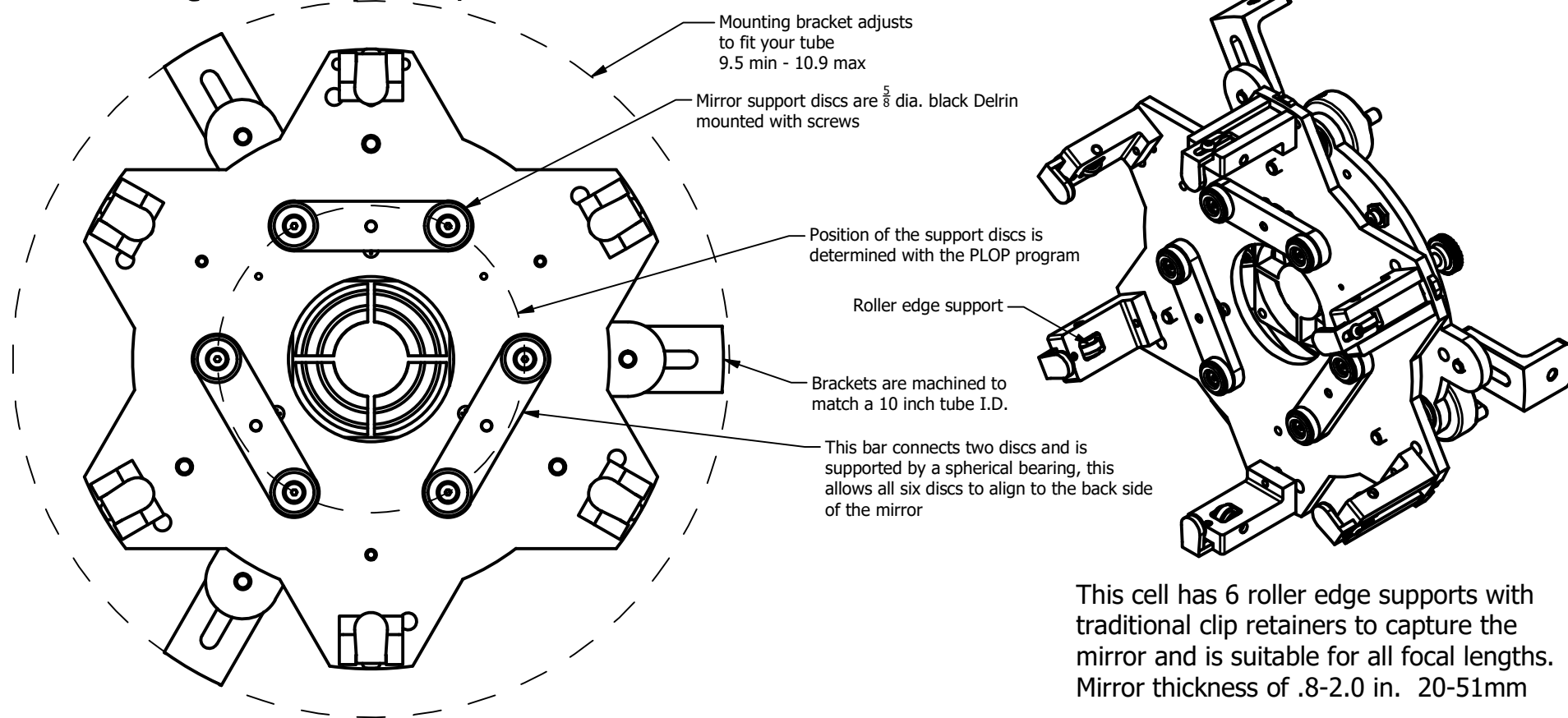

Images shown are from a full scale model

Weight is 4 lbs, 8 oz - 2.01Kg
Shown with fan installed

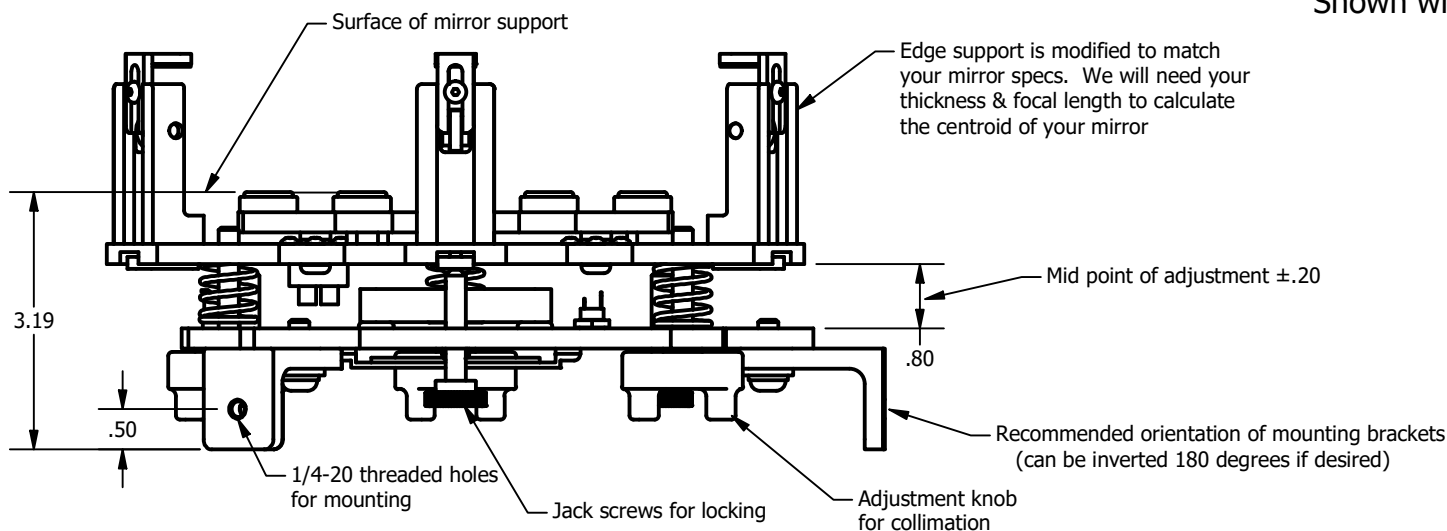

www.aurorap.com
6644 SE Jerry Drive
Prineville, Oregon 97754
541-362-5965
EQ-8 tube spec sheet Rev1 5-22-2020
All dimensions are in inches