

Model #EQ-15 Six point, tube mount mirror cell for an 15 inch mirror

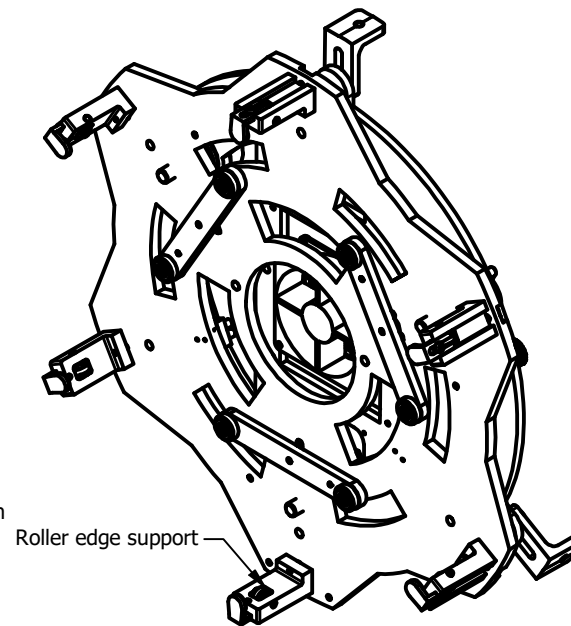
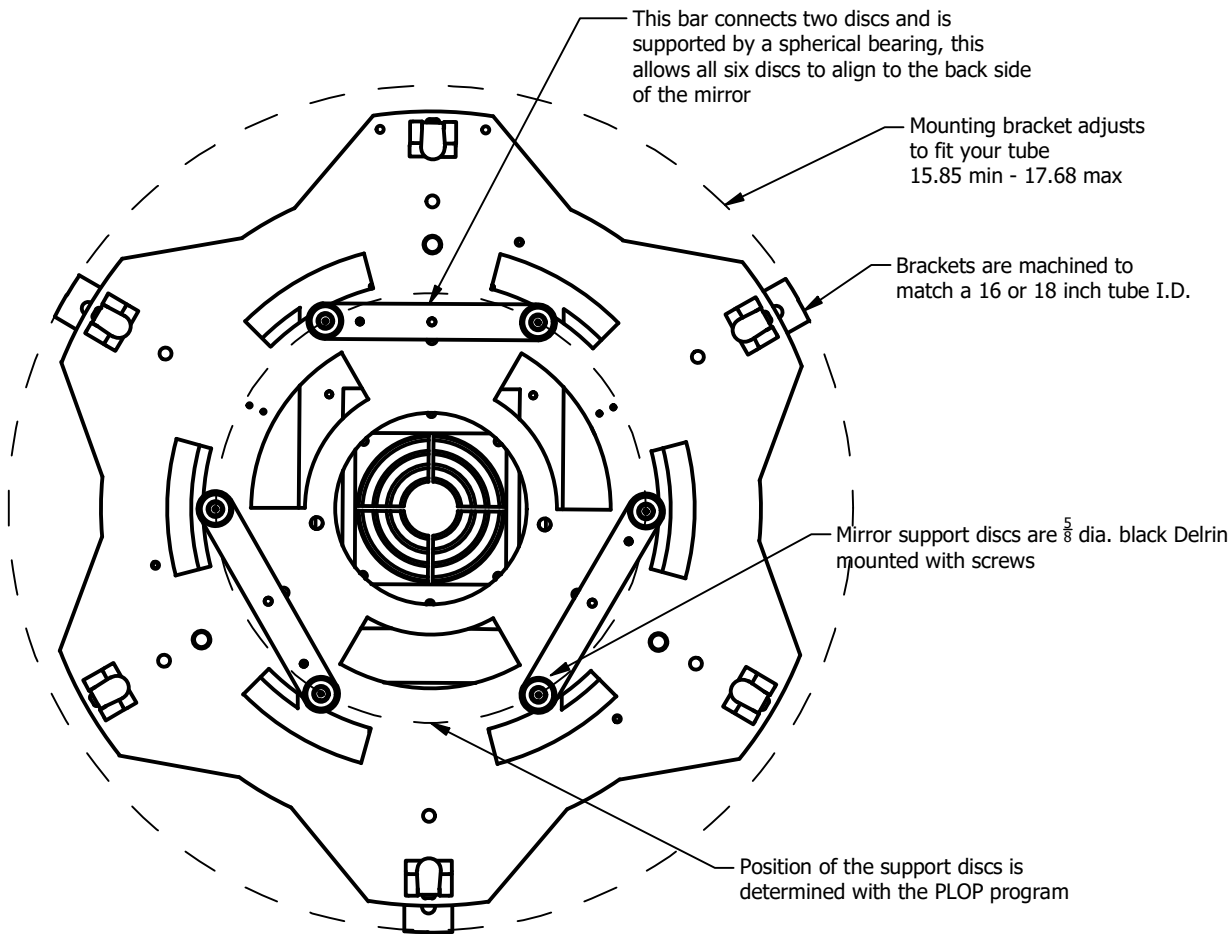

This cell has 6 roller edge supports with traditional clip retainers to capture the mirror and is suitable for all focal lengths. Mirror thickness of .8-2.0 in. 20-51mm

Weight is 9 lbs, 5 oz - 4.228 Kg
Shown with fan installed

Images shown are from a full scale model

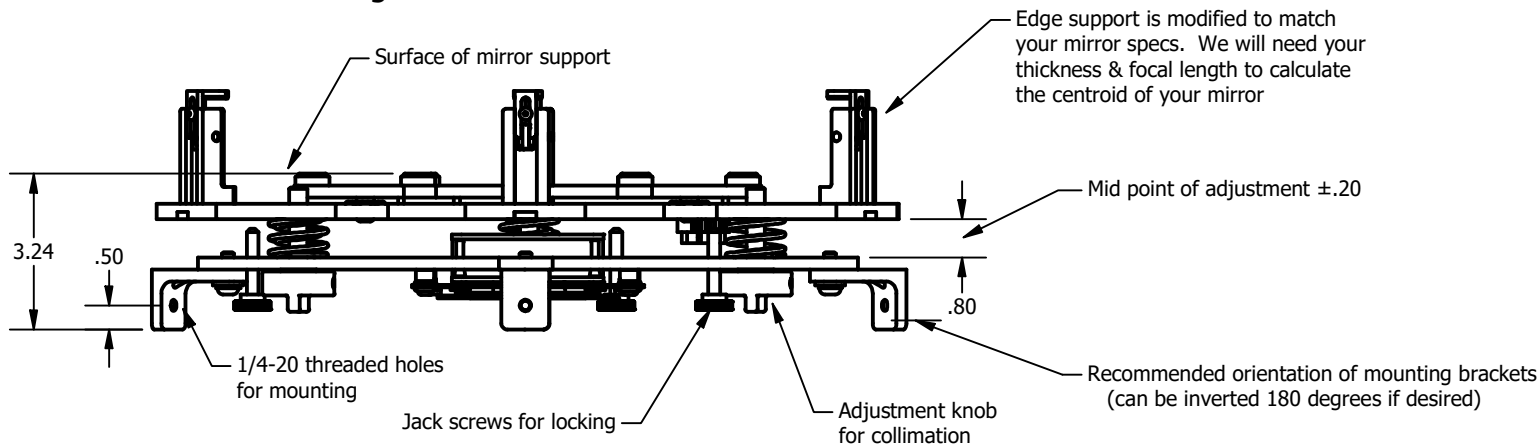

www.aurorap.com
6644 SE Jerry Drive
Prineville, Oregon 97754
541-362-5965
EQ-15 tube spec sheet Rev1 11-11-2020
All dimensions are in inches