

# Model #EQ-13.1 Six point, tube mount mirror cell for a 13-13.1 inch mirror

Position of the support discs is determined using the PLOP program

Mounting bracket adjusts to fit your tube  
14.75min - 16.25 max

Mounting brackets are machined to match a 15 inch tube

Mirror support discs are  $\frac{5}{8}$  black Delrin  
Mounted with screws

This bar connects two discs and is supported by a spherical bearing, this allows all six discs to align to the back side of the mirror

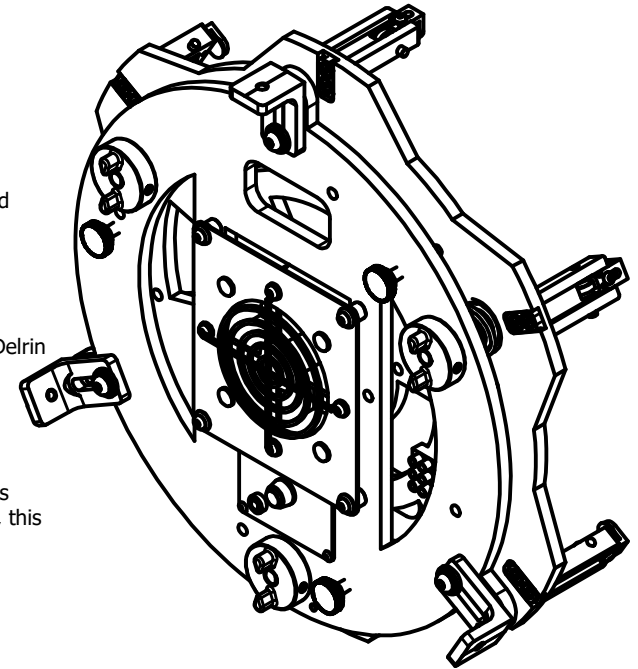

This cell has 6 roller edge supports with traditional clip retainers to capture the mirror and is suitable for all focal lengths. Mirror thickness of .8-2.0 in. 20-51mm

Weight is 8 lbs, 2 oz - 3.68Kg  
Shown with fan installed

Images shown are from a full scale model

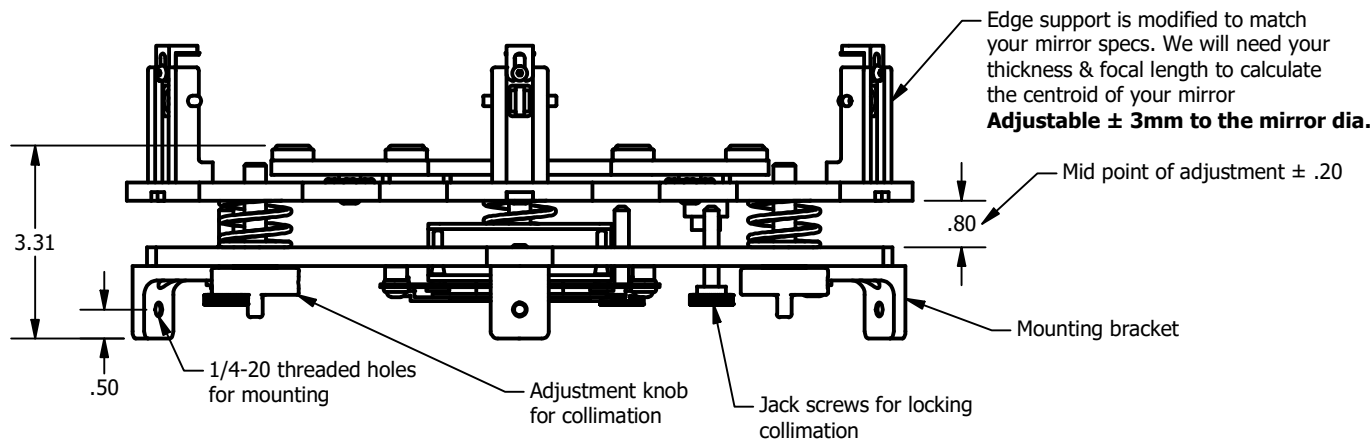

www.aurorap.com  
6644 SE Jerry Drive  
Prineville, Oregon 97754  
541-362-5965  
EQ-13.1 tube spec sheet Rev1 3-4-2024  
All dimensions are in inches