

Model #EQ-11 Six point, tube mount mirror cell for an 11 inch mirror

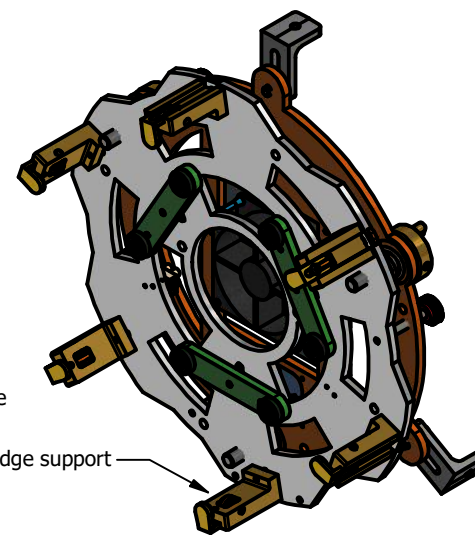
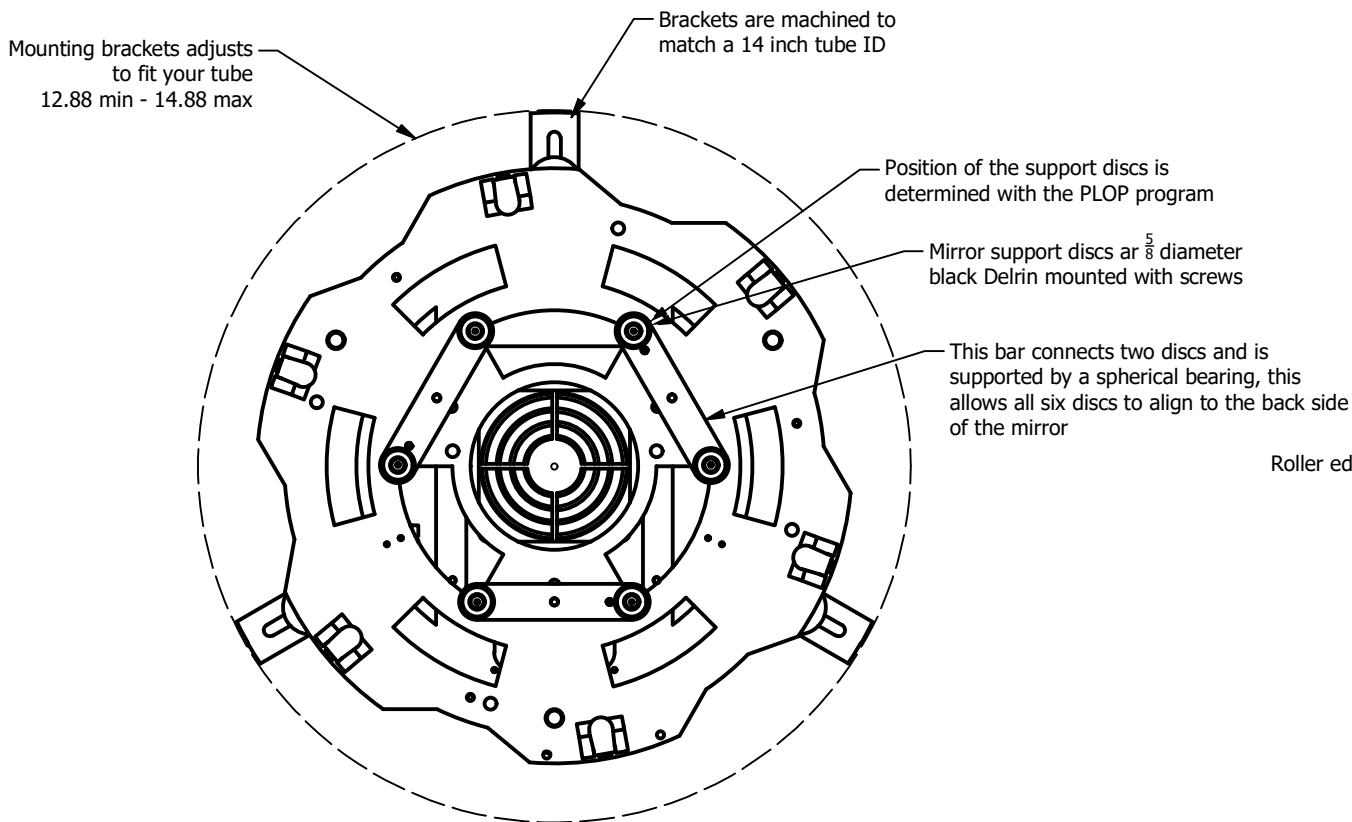

This cell has 6 roller edge supports with traditional clip retainers to capture the mirror and is suitable for all focal lengths. Mirror thickness of .8-2.0 in. 20-51mm

Images shown are from a full scale model

Weight is 5 lbs, 5 oz - 2.41Kg
Shown with fan installed

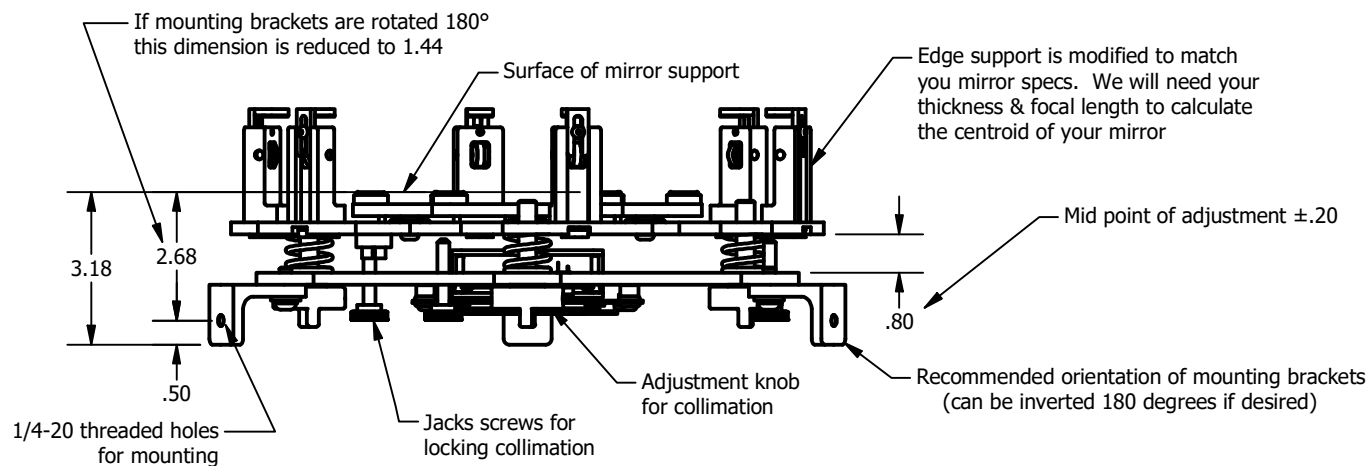

www.aurorap.com

6644 SE Jerry Drive

Prineville, Oregon 97754

541-362-5965

EQ-11 tube spec sheet Rev1 12-7-2021

All dimensions are in inches