

Model AZ-14.5 Six point, Box mount mirror cell

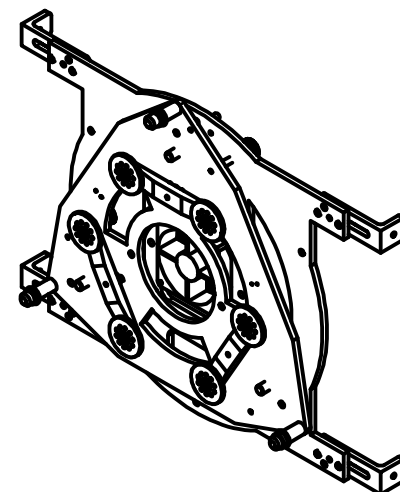
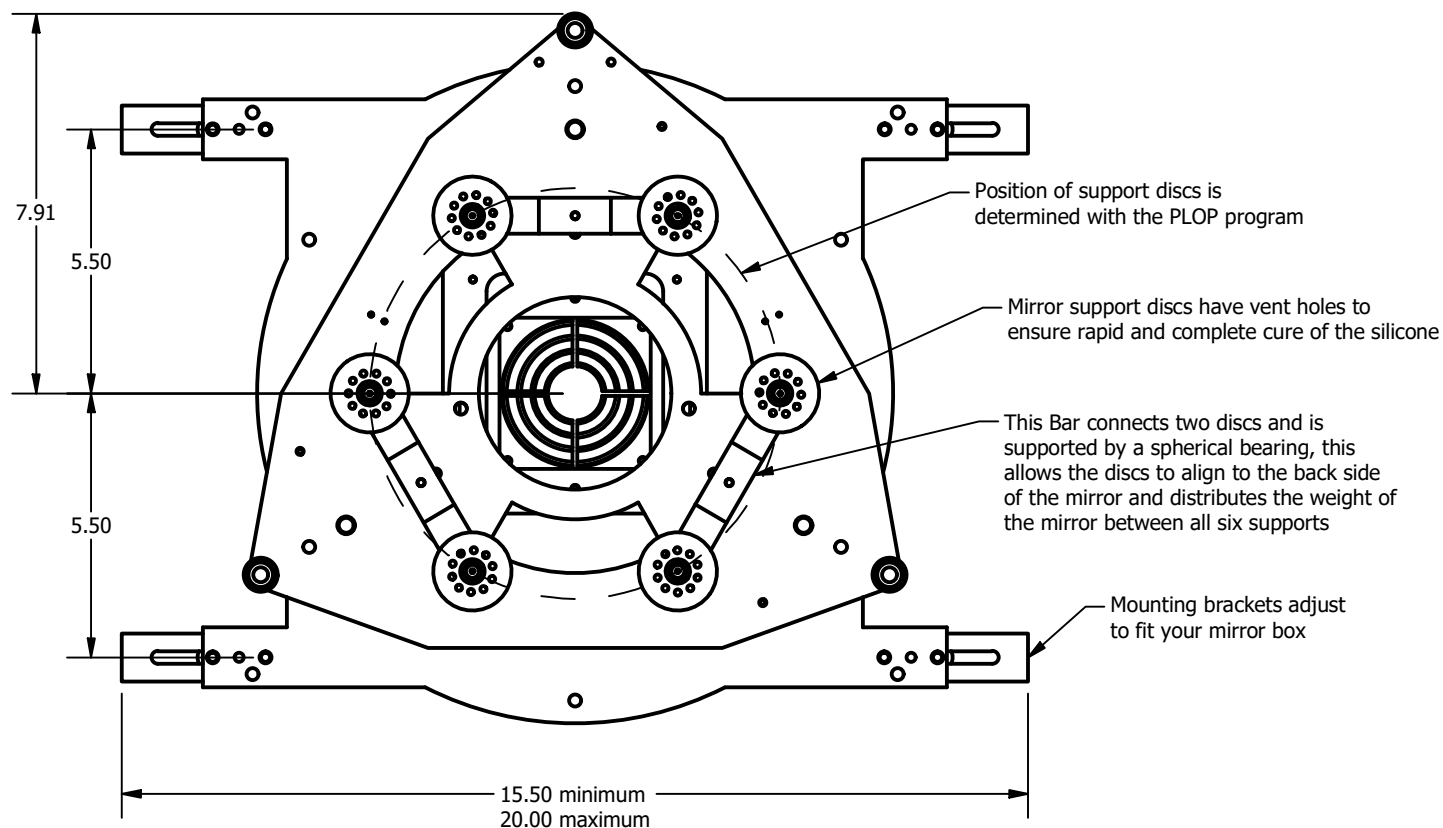

This cell uses silicone RTV to hold the mirror in place and is suitable for all focal lengths, and thickness of 1 - 1.95 inches.

Weight is 6 lbs, 8 oz - 2.95Kg
Shown with fan installed

Images shown are from a full scale model

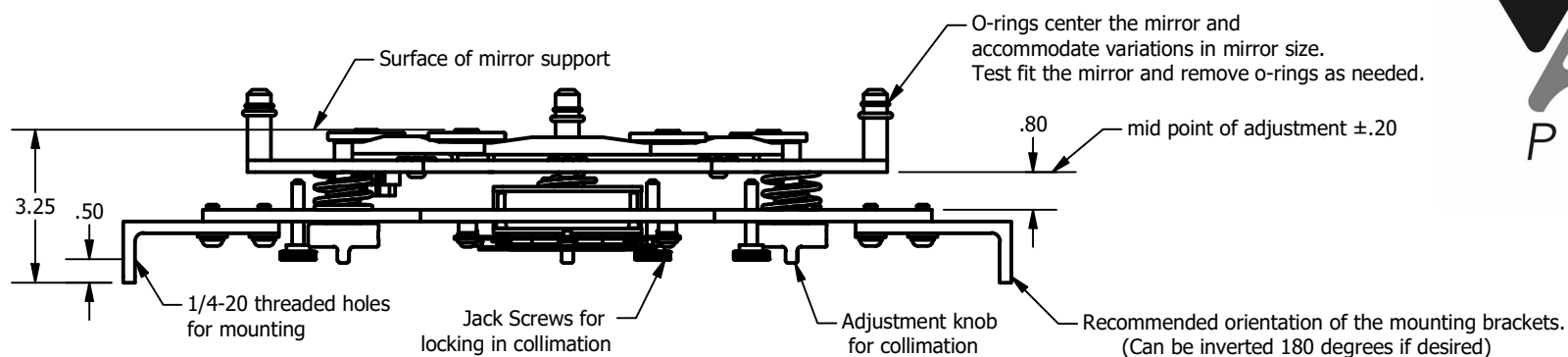

www.aurorap.com
6644 SE Jerry Drive
Prineville, Oregon 97754
541-362-5965

AZ-14.5 spec Box sheet Rev2 12-26-19
All dimensions are in inches