

Model #AZ-12.5 Six point, Box mount mirror cell

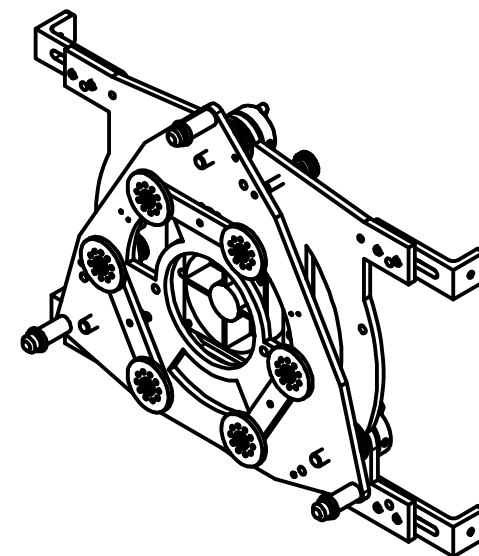
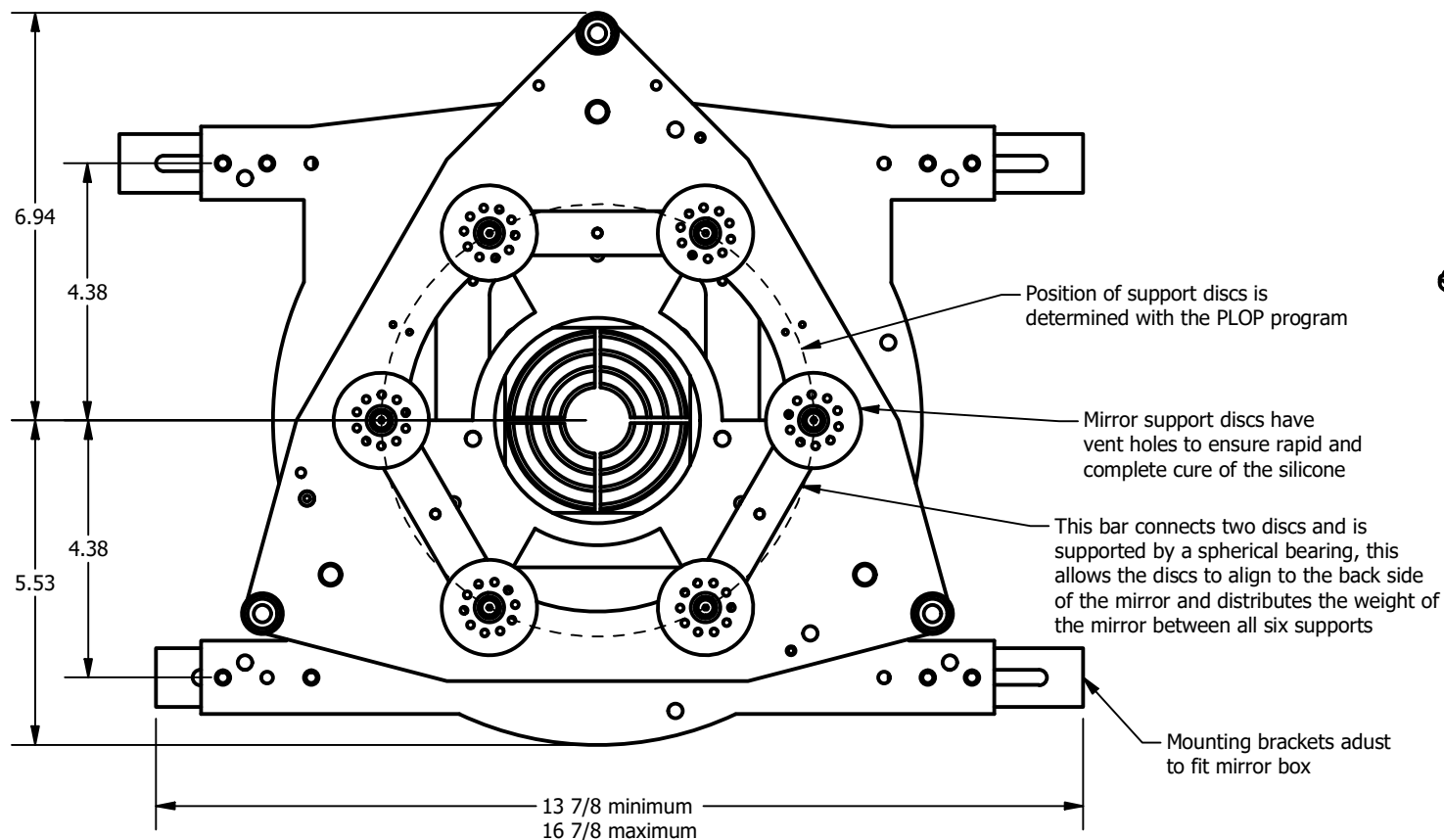

This cell uses silicone RTV to hold the mirror in place and is suitable for all focal lengths and thickness of .70 - 1.95 inches.

Weight is 5 lbs, 6 oz - 2.44Kg
Shown with fan installed

Images shown are from a full scale model

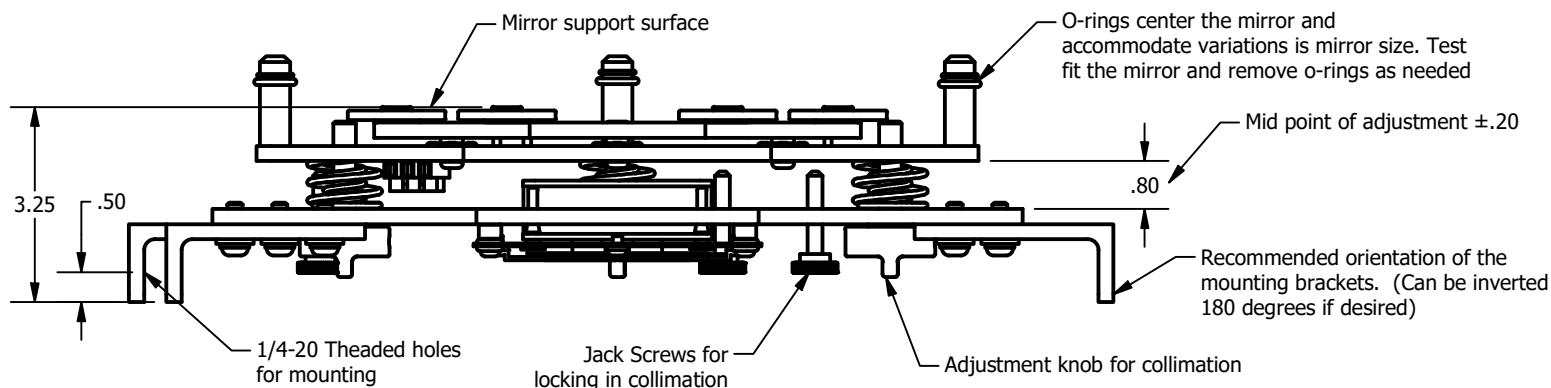

www.aurorap.com
6644 SE Jerry Drive
Prineville, Oregon 97754
541-362-5965

AZ-12.5 Box spec sheet Rev5 1-2-2020
All dimensions are in inches