

# Model #AZ-12 Six point, Box mount mirror cell

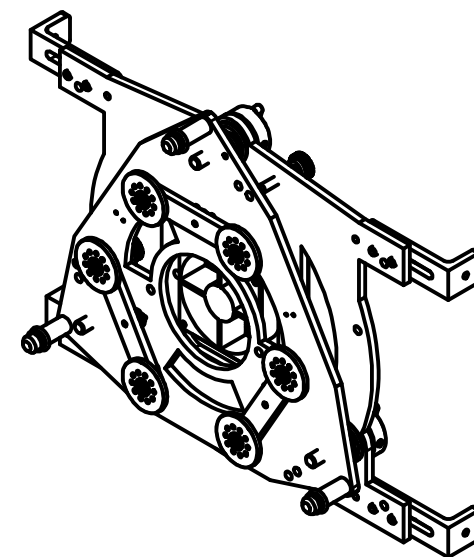
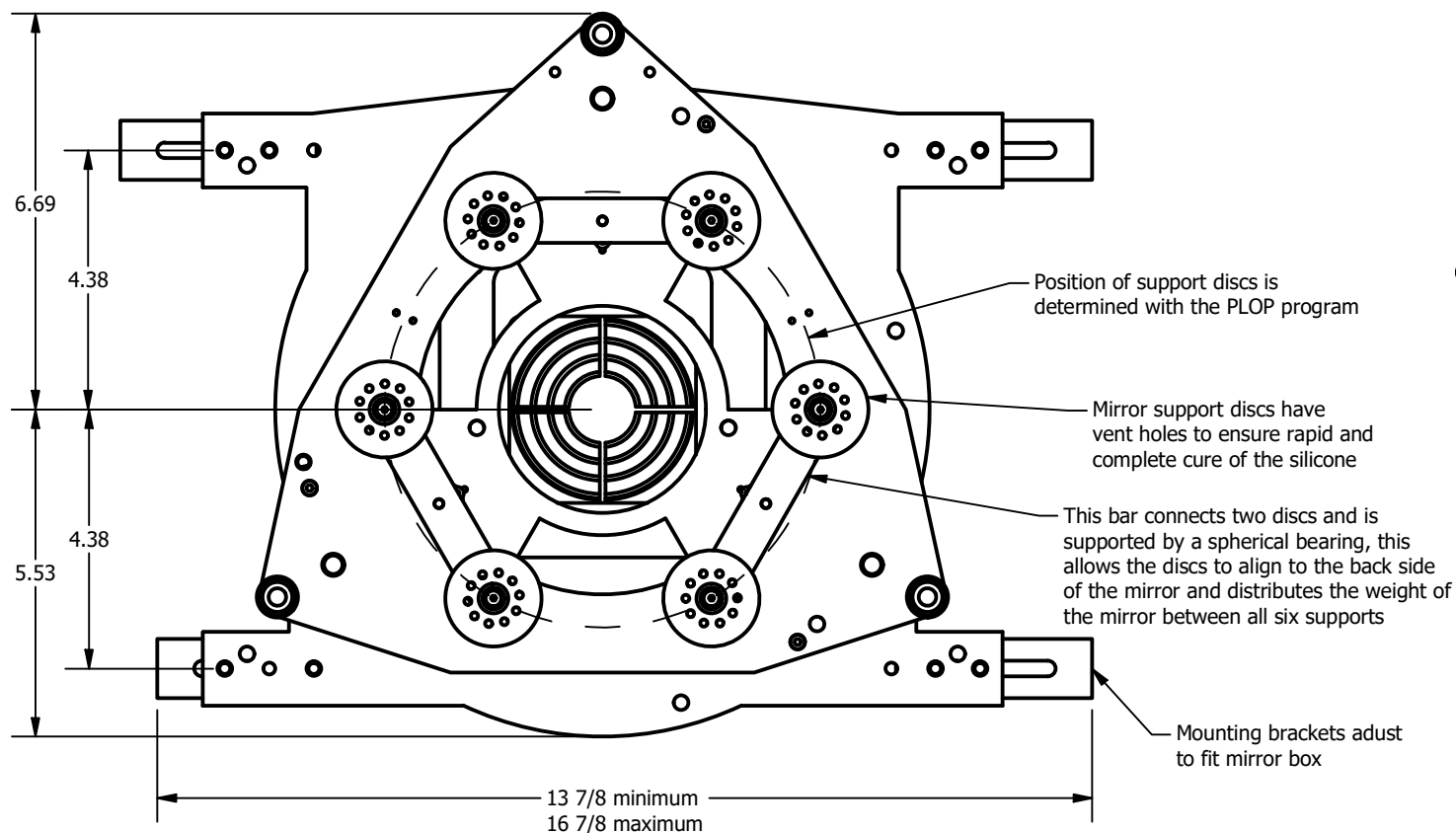

This cell uses silicone RTV to hold the mirror in place and is suitable for all focal lengths and thickness of .70 - 1.95 inches.

Weight is 5 lbs, 4 oz - 2.38Kg  
Shown with fan installed

Images shown are from a full scale model

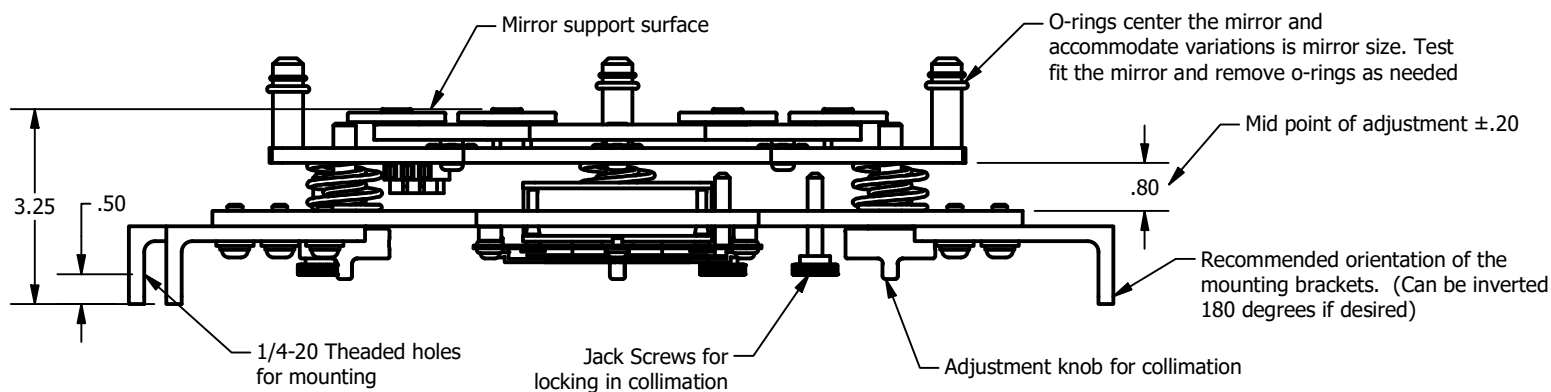

www.aurorap.com  
6644 SE Jerry Drive  
Prineville, Oregon 97754  
541-362-5965

AZ-12 Box spec sheet Rev1 1-2-2020  
All dimensions are in inches