

# Model #AZ-10 Six point, tube mount mirror cell for an 10 inch mirror

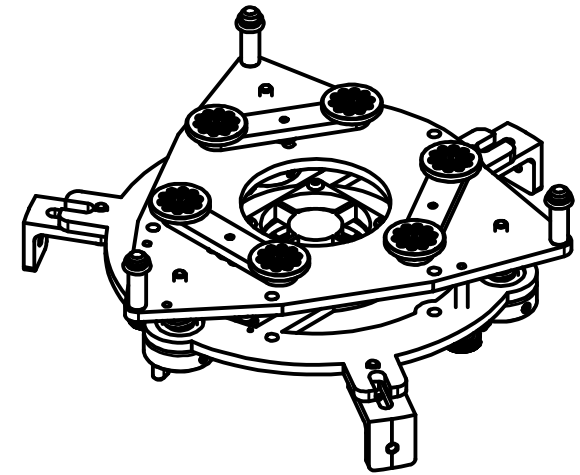
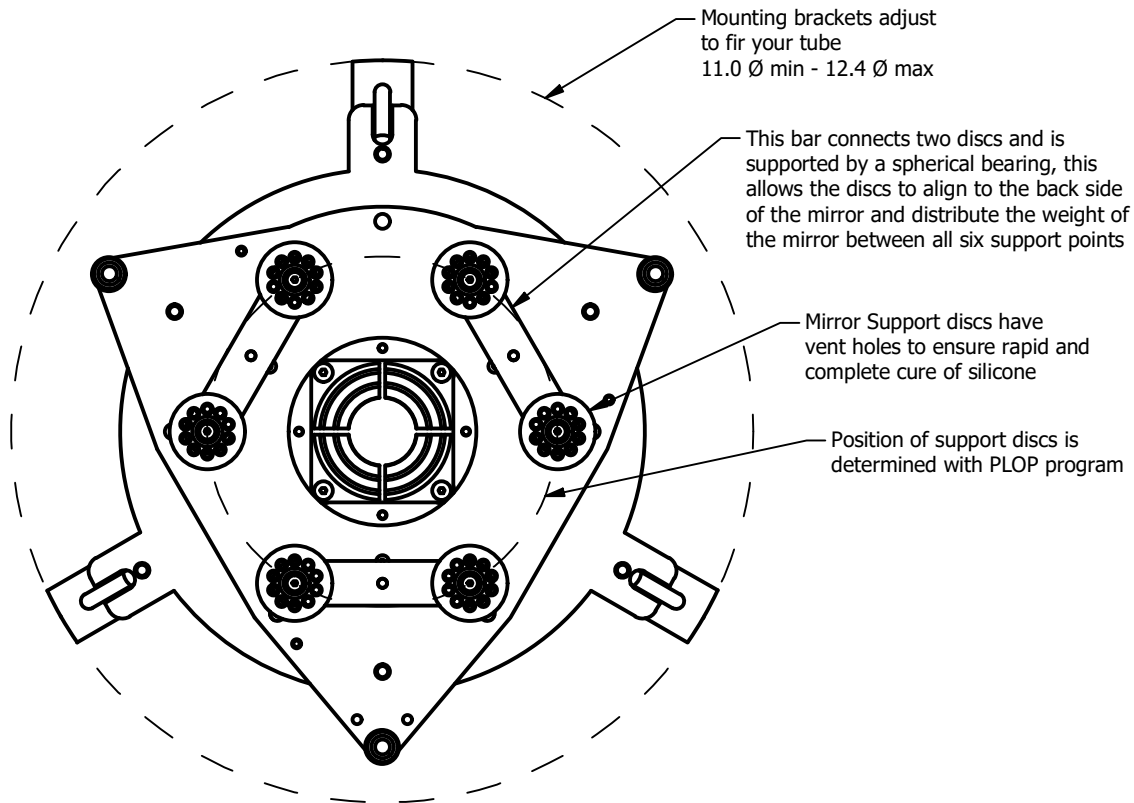

This cell uses silicone RTV to hold the mirror in place and is suitable for all focal lengths, and thickness of .70 - 1.95 inches.

Images shown are from a full scale model

Weight 3 lbs 8 oz - 1.59 Kg  
Shown with fan installed

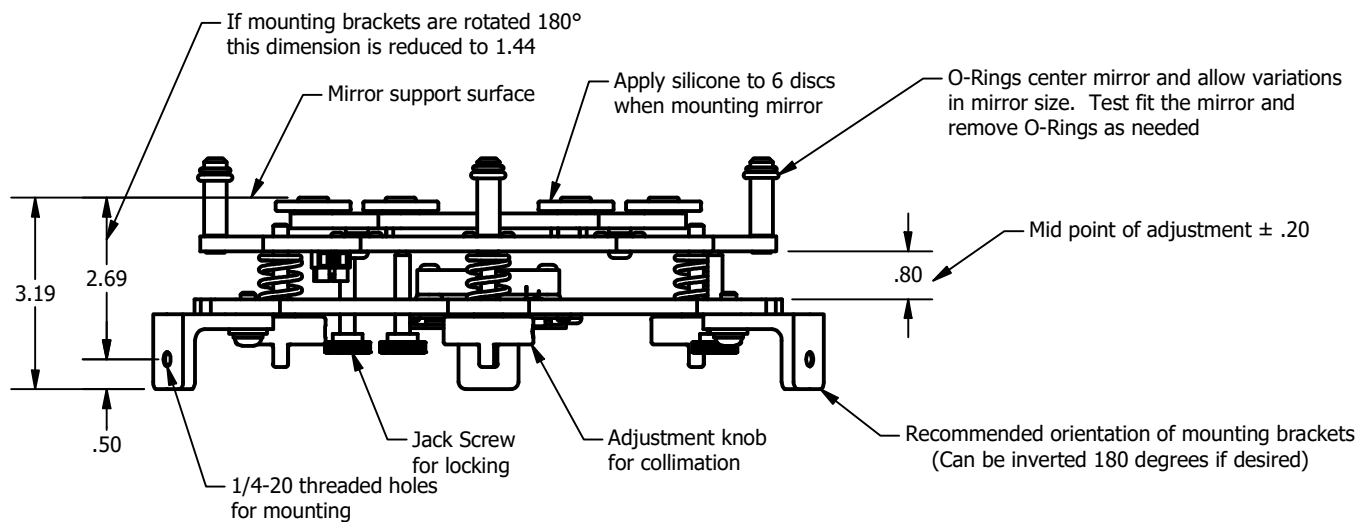

www.aurorap.com  
6644 SE Jerry Drive  
Prineville, Oregon 97754  
541-362-5965

AZ-10 tube spec sheet Rev5 7-13-21  
All dimensions are in inches